



## Contact Us

---

-  Enertec Batteries (Pty) Ltd
-  [www.enertecenergy.co.za](http://www.enertecenergy.co.za)
-  031 701 7761
-  [brettd@enertec.co.za](mailto:brettd@enertec.co.za)

# Off-grid All-in-one Energy Storage System User Manual

Model No: GE0405, GE0610, GE0810 | Version: V1.0

Enertec Batteries (Pty) Ltd

# Contents

## Overview

Thank you for choosing GE series energy storage system. The system has innovative design and perfect quality management. The operation is safe, stable, reliable and has a long service life. At the same time, the product is easy to operate and use, and has a series of perfect protection functions.

This manual is mainly about the safe operation of the system. Please read this manual carefully before operation. If encounter any problems during the operation of the equipment, please refer to the appropriate instructions to solve most of the problems in installation and operation. If necessary, please contact the distributor or supplier.

<b>Part 1 Safety</b>	<b>05</b>
1.1 Safety announcements	05
1.2 Operation requirements	11
1.3 Operation environment requirements	11
<b>Part 2 Product Introduction</b>	<b>11</b>
2.1 Product model and function description	12
2.2 Product appearance	13
2.3 Product dimension	13
2.4 System composition schematic diagram	13
2.5 System panel introduction	14
2.6 System nameplate	17
<b>Part 3 Product Installation</b>	<b>20</b>
3.1 Equipment List	20
3.2 Notes before Installation	21
3.3 Tool Preparation	22
3.4 System Installation	23
<b>Part 4 Electrical Connection</b>	<b>31</b>
4.1 Circuit schematic diagram	31
4.2 PV wiring	31
4.3 AC wiring	33
4.4 Communication wiring	36
4.5 Diesel generator connection	37
4.6 Ground wiring	39
<b>Part 5 Operation Instruction</b>	<b>40</b>
5.1 Working mode	40
5.2 Statement of operation	40
5.3 GE series all-in-one machine switch operation	41
5.4 Display status	43
<b>Part 6 Maintenance and Common Fault Treatment</b>	<b>44</b>
6.1 Daily maintenance	44
6.2 Common trouble shooting	44
<b>Part 7 Packing, Transportation and Storage</b>	<b>46</b>
7.1 System packing	46
7.2 System handling and transportation	46
7.3 System store	46
<b>Appendix: Parameters</b>	<b>47</b>





# Part I. Safety





## I.1 Safety Announcements

### I.1.1 Safety Instructions







When installing, using and maintaining this product, please read the manual carefully and operate in accordance with the safety precautions required by the manual. The safety considerations mentioned in this manual are only complementary to local safety codes.

Any injury or loss caused by illegal operation has nothing to do with us.

Unpacking inspection	 <b>Warning</b>
	<ul style="list-style-type: none"> <li>• If the product is found to be damaged or missing parts, it can't be installed, or failure may occur.</li> <li>• If the packing list does not match the physical name, please do not install it and contact the distributor in time.</li> </ul>
Installation	 <b>Danger</b>
	<ul style="list-style-type: none"> <li>• Wiring must be carried out by electrical engineers, or there is a risk of electric shock or damage to the system.</li> <li>• Make sure that the power supply is disconnected before wiring, or there is a risk of electric shock or fire.</li> <li>• The installed cable must meet the requirements, and the distribution part must comply with the safety specification.</li> <li>• The installation must be carried out strictly according to the installation steps in the following chapters, or the product will be damaged.</li> </ul>
	 <b>Warning</b>
	<ul style="list-style-type: none"> <li>• Please lift and handle gently during handling and installation so as not to hurt your foot or damage the product.</li> <li>• This system must stay away from flammable objects and heat sources.</li> <li>• Do not drop sundries into the system when installing, or it may cause system failure.</li> </ul>
Operation	 <b>Danger</b>
	<ul style="list-style-type: none"> <li>• During normal operation, direct contact with output, input and other terminals is strictly prohibited to avoid the danger of electric shock.</li> <li>• During normal operation, do not open the machine shell directly, or it will cause electric shock.</li> </ul>

Operation	 <b>Warning</b>
	<ul style="list-style-type: none"> <li>• Before running, please make sure that this product is used within the allowable working range, or it will cause damage to this product.</li> <li>• When not using this product for a long time, it is necessary to discharge the battery capacity to between 45% and 60%, and disconnect the battery output to avoid emptying the battery.</li> </ul>
Maintenance and overhaul	 <b>Danger</b>
	<ul style="list-style-type: none"> <li>• When removing the shell, be sure to disconnect the input and output circuits, or there is a risk of electric shock.</li> <li>• Even after the shell is removed, there is still residual power inside the machine. Do not touch the exposed part of the circuit directly to avoid causing electric shock.</li> <li>• Maintenance and overhaul must be carried out by professional maintenance personnel. Users must not dismantle the machine by themselves to avoid electric shock and product damage.</li> </ul>
Transport	 <b>Danger</b>
	<ul style="list-style-type: none"> <li>• In the process of transportation, this product should avoid strong vibration, falls and bumps, and it is strictly forbidden to turn the packing box upside down. when unpacking, do not lose accessories, user manuals, warranty cards, etc.</li> </ul>
	 <b>Warning</b>
	<ul style="list-style-type: none"> <li>• Please pay attention to safety when carrying, so as not to harm your body.</li> </ul>
Other	 <b>Danger</b>
	<ul style="list-style-type: none"> <li>• It is forbidden to self-modify the system so as not to cause serious accidents.</li> <li>• If there is an anomaly inside the machine, please disconnect the power supply and load immediately.</li> </ul>

I.1.2 Device Label Illustration

Symbol	Interpretation
	<b>Warning!</b> Due to the danger caused by failure to operate in accordance with the requirements, it may lead to moderate personal injury or minor injury, as well as damage to the product!
	Danger: high voltage danger beware of electric shock!
	CB Certification
	High temperature of product air outlet, be careful to touch it!
	Wait 5 minutes after the power outage to ensure that the machine is fully discharged!
	The product can not be discarded with other domestic waste, must be sent to the appropriate organization for recovery and recycling!
	Please read the manual carefully before using it!

I.1.3 SPD Protection

	<b>Warning!</b> Over-voltage protection with surge arresters should be provided when the Energy Storage System(ESS) is installed.
---	--

- Lighting can cause damage either from direct strike or from surges due to a nearby strike.
- Induced surges are the more likely cause of lighting damage in majority or installations, especially in rural areas where electricity is usually by long overhead lines. Surge may be included on both the PV array conduction and the A.C. cables leading to the building.
- Specialists in lighting protection should be consulted during the end use application. Using appropriate external lighting protection, the effect of a direct lightning strike into a building can be mitigated in a controlled way, and the lightning current can be discharged into the ground.
- Installation of SPDs to protect the ESS against mechanical damage and excessive stress include a surge arrester in case of a building with external lightning protection system (LPS) when separation distance is kept.
- To protect the D.C. system, surge suppression device (SPD type2) should be fitted at the ESS end of the D.C. cabling and at the array, located between the ESS and the PV generator, if the voltage protection level (VP) of the surge arresters is greater than 1100V, additional SPD type 3 required for surge protection for electrical devices.
- To protect the A.C. system, surge suppression devices (SPD type2) should be fitted at the main incoming point of A.C. supply (at the consumer's cutout), located between the ESS and the meter/distribution system; SPD (test impulse D1) for signal line according to EN 61632-1.
- All D.C. cables should be installed to provide as short runs as possible, and positive and negative cables of the same string or main D.C. supply should be bundled together. Avoiding the creation of loops in the system. This requirement for short runs and bundling includes any associated earth/bundling conductors.
- Spark gap devices are not suitable to be used in D.C. circuits as once conducting, they won't stop conducting until the voltage across their terminals is typically more than 30 volts.

### 1.1.4 ESD Protection

- Before carrying out the maintenance work, please power off the system and wait at least 5 minutes, then operate the system.
- Please observe the electrostatic protection specification during the operation and maintenance of the system.
- For personal safety, please wear insulating gloves, anti-smashing shoes and electrostatic rings.

### 1.1.5 Grounding Requirements

- The end-use application shall monitoring of the protective conductor by residual current operated protective device (RCD) with rated fault current if  $n \leq 300\text{mA}$  which automatically disconnects the device in case of a fault.
- DC differential currents are created (caused by insulation resistance and through capacities of the PV generator). In order to prevent unwanted triggering during operation, the rated residual current of the RCD has to be min 300mA.

	<p><b>Warning!</b> Over-voltage protection with surge arresters should be provided when the Energy Storage System (ESS) is installed.</p>
---	---

- Incorrect grounding can cause physical injury, death or equipment malfunction and increase electromagnetic.
- Make sure that grounding conductor is adequately sized as required by safety regulations.
- Do not connect the ground terminals of the unit in series in case of a multiple installation. This product can cause current with a D.C. component, where a residual current operated protective (RCD) or monitoring (RCM) device is used for protection in case of direct or indirect contact, only an RCD or RCM of type B is allowed on the supply side of this product.

	<p><b>Warning!</b> Do not work on the ESS when the device is running.</p>
---	---

- Never touch either the positive or negative pole of PV or battery connecting device. And never ever touch both at the same time.

	<p><b>Warning!</b> Risk of electric shock!</p>
---	--

- The unit contains capacitors that remain charged to a potentially lethal voltage after the MAINS, battery and PV supply has been disconnected.
- Hazardous voltage will present for up to 5 minutes after disconnection from power supply.
- CAUTION-RISK of electric shock from energy stored in capacitor, never work on the solar ESS couplers. The MAINS cable, Battery cable, PV cables or the PV generator when power is applied. After switching off the PV, battery and Mains, always wait for 5 minutes to let the intermediate circuit capacitors discharge before you unplug DC, battery plugs and MAINS couplers.
- When access to internal circuit of solar inverter, it is very important to wait 45 minutes before working on power circuit or demounting the electrolyte capacitors inside the device. Do not open the device before hand since the capacitors require this long to discharge sufficiently!

### 1.1.6 Moisture Proof Protection

- Please make sure that the installation environment of the system is well ventilated. The distance between the system and the surrounding objects should meet the installation requirements of 3.2, to ensure adequate installation and heat dissipation space.
- If you have any questions about this, please consult the distributor's technical service engineer.
- Prevent the system from direct sunlight, rain and snow, which can prolong the service life of the system.

### 1.1.7 Warning Mark Setting

- The warning sign on the system box contains important information for safe operation, man-made damage is strictly prohibited.
- The side of the system box is affixed with a nameplate, which contains important parameter information related to the product, man-made damage is strictly prohibited.

### 1.1.8 Electrical Connection

- Before installing the system, make sure that it is not electrically connected and powered on.
- All electrical connections must meet the electrical standards of the country in which they are located.

- The cables used in the system must be securely connected, well insulated and of appropriate specifications.
- The system can be connected to the grid only with the permission of the power department of the country in which it is located.

### 1.1.9 Measurement Under Operation

- Please make the measurement under the condition that you are familiar with and understand the contents of this manual and have the appropriate tools and testing equipment.
- In the process of measurement, please try to avoid irrelevant personnel touch the equipment, so as to avoid the danger of electric shock.
- Please comply with the relevant electrical specifications in the process of measurement.

### 1.2 Operation Requirements

	<p><b>Danger!</b></p> <p>During the operation of the system, there is a high voltage, which may lead to electric shock, and death in serious cases. Please strictly follow the safety precautions listed in this manual and other related documents.</p>
---	--

- All operations for the system must be carried out by trained professional electrical technicians.
- Operators should be fully familiar with the composition and working principle of the entire energy storage power generation system, and the relevant standards of the country where the project is located, and comply with local regulations and codes.
- When the system is running, the temperature of the system outlet may exceed 60 °C. there is a risk of burns, please do not touch it.
- When the system is working, it is forbidden to plug and unplug PV, battery, AC cable and so on.

### 1.3 Operation Environment Requirements

- The protection grade of this system is IP20, which can only be installed and run indoors.
- Do not store flammable and explosive materials in the attachment area of the system.
- It is recommended that the operating ambient temperature be kept below 35°C to ensure that the system operates at its best.
- The system should operate in a well-ventilated environment to ensure good heat dissipation.
- Do not drench or spray water on the system during operation to avoid the risk of short circuit.

## Part 2. Product Introduction

This product uses lithium battery, solar charging controller and inverter modular all-in-one design to realize the energy flow control of optical storage and charging, and the automatic switching of off-grid, grid-connected and diesel generators. Residential energy storage system consists of the following parts: solar charging controller, energy storage inverter, lithium battery, EMS.

The system supports a variety of working modes, and can give priority to the use of photovoltaic and energy storage to supplement energy supply load. It can give priority to the grid with load, photovoltaic supplement, energy storage battery as a backup power supply; at the same time, it supports seamless switching for on&off-grid operation; it can also be set up according to the needs of one-button charging function and intelligent mode charging and so on.

### 2.1 Product model and function description

#### 2.1.1 Residential energy storage system

GE0610 is specially developed for users in the areas of no power and little power.

It adopts the design concept of integration, which integrates the modules of energy storage battery, PV controller, energy storage inverter, energy management unit and intelligent terminal control.



GE0610



GE0810

#### 2.1.2 Industrial and commercial energy storage system

GE0810 is specially developed for users in the areas of no power and little power. It adopts the design concept of integration, which integrates the modules of energy storage battery, PV controller, energy storage inverter, energy management unit and intelligent terminal control.



### 2.2 Product Appearance

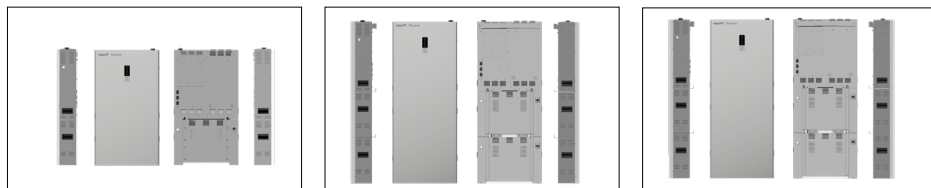

GE0405 5.12kWh ESS

GE0610 10.24kWh ESS

GE0810 10.24kWh ESS

### 2.3 Product Dimension

	H	W	D
GE0405	1160mm	650mm	214mm
GE0610	1620mm	650mm	214mm
GE0810	1620mm	650mm	214mm

### 2.4 System composition schematic diagram

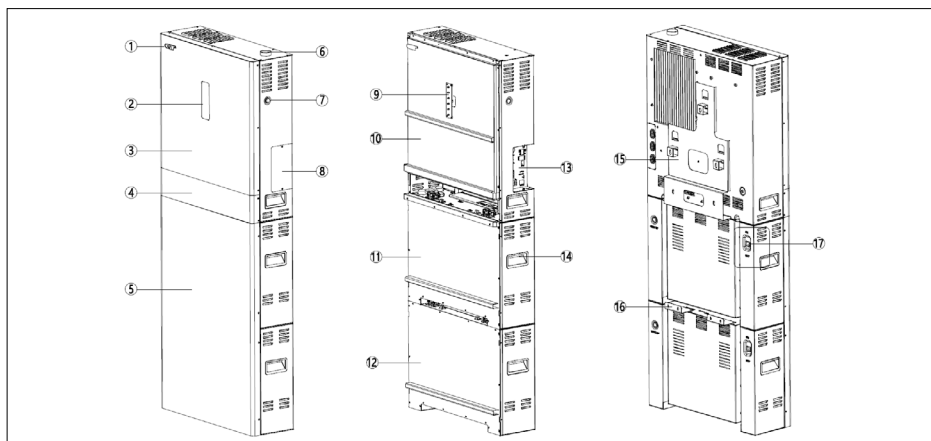

- ① Logo    ② Indicator    ③ Front cover plate(top)    ④ Front cover plate(middle)
- ⑤ Front cover plate(bottom)    ⑥ WIFI Antenna    ⑦ Power switch button
- ⑧ User wiring panel cover    ⑨ Display board    ⑩ Inverter    ⑪ 1#battery    ⑫ 2#battery
- ⑬ User wiring panel    ⑭ Handle    ⑮ Wall hanging shelf    ⑯ Fixed frame    ⑰ Battery switch

### 2.5 System panel introduction

2.5.1 The user wiring panel of GE series all-in-one machine (remove terminal cover plate), shown in the following figure.

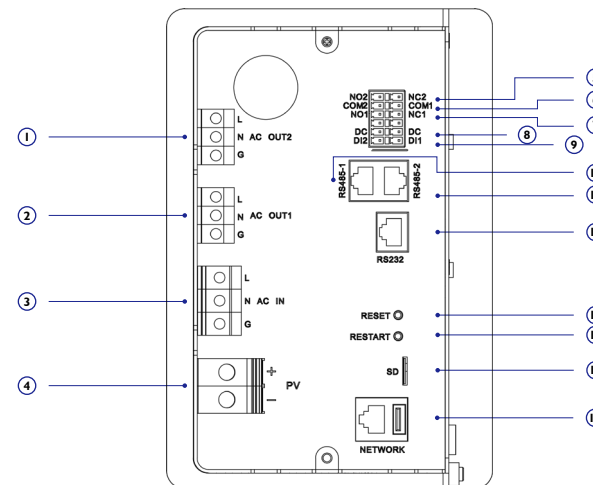

No.	ITEM	Description
1	AC OUT2	AC output terminal for universal load
2	ACOUT I	AC output terminal for critical load
3	AC IN	AC input terminal for DG or utility grid
4	PV	PV input terminal
5	NO2	Normally Open Contact (reserved for DG connection)
	NC2	Normally Closed Contact (reserved for DG connection)
6	COM	Common Contact
7	NO1	Normally Open Contact (used for inverter connection)
	NC1	Normally Closed Contact (used for inverter connection)
8	DC	Reserved
9	DII	Reserved
10	RS485 I	EMS and BMS communication connection line
11	RS4852	EMS and inverter communication connection line
12	RS232	Debug serial port
13	RESET	System reset button
14	RESTART	System restart button
15	SD	SD card slot
16	NETWORK	RJ45 interface for Ethernet connection, USB port for software update by USB driver

2.5.2 The battery box panel is illustrated as shown in the following figure:

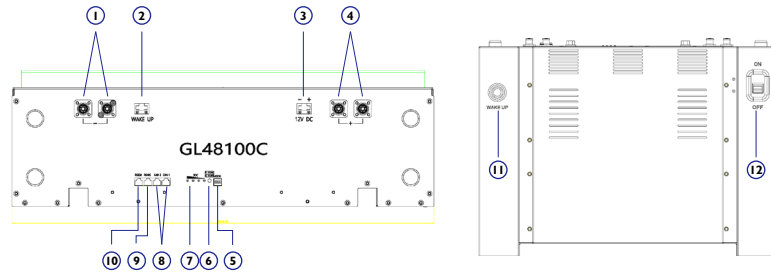

① Negative pole(-)

Two black negative terminals connected internally with identical specifications, one terminal is reserved for capacity extension by parallel connection.

② Wake up socket(wake up)

After bridging over the socket , the whole battery will be automatically powered on and woke up. The plug switch ACTS as a key switch function, can switch on or off the battery.

③ 12V switch power input(12 vdc)

When the battery is seriously over discharged, it enters the low-power mode; External connection of 12V DC power supply is needed to charge the system to wake up the whole system.

(Note: Please pay attention to avoid serious over-discharged of the battery If it exceeds the applicable scope of the manual, it will not be covered by the warranty conditions.

④ Positive pole(+)

Two black positive terminals connected internally with identical specifications, one terminal is reserved for capacity extension by parallel connection.

⑤ Dip switch(ADDR)

When the battery are used in parallel, different battery can be distinguished by the hardware address, and the hardware address of each battery box in the parallel system is unique. The hardware address can be set in turn by the dial switch on "ADDR".

(Note: Please refer to the following 2.5 communication instructions for specific setting and operation).

⑥ Status indicator(R-ALM/G-RUN)

RUN operation status indicator: when battery work normally, light display green;

ALM abnormal state indicator: when any alarms occur, it display yellow, when system is fault and enter into protection state, it displays red.

⑦ Electricity energy(SOC)

SOC power display light: When the battery is running normally, the LED green light shows current SOC of battery.

⑧ CAN communication(CAN1/CAN2)

The battery has a CAN port. When the battery is used in parallel, the master battery communicates with the slave battery through the CAN port.

⑨ RS485 communication(RS485)

The battery has an RS485 interface, and the battery communicates with the EMS via the RS485 interface, so as to upload the parameter information of each parallel battery to the EMS. At the same time, it can also be connected to the upper computer through the RS485 interface for parameter reading and setting.

⑩ RS232 communication(RS232)

The battery can communicate with the upper computer through RS232 interface, so as to monitor all kinds of information of the battery, including battery voltage, current, temperature, state, SOC, SOH and battery production information, etc., at the upper computer end. The default baud rate is 9600 bps.

(Note: RS232 upper computer is only for R&D use, service client is not supported).

⑪ Wake up button(Reserved terminal)

After closing this switch, the whole battery box will be automatically self-checked to power up and wake up, and the whole battery will be automatically shut down. This button switch acts as the main power switch function, which can control the switch on or off the battery.

(Note: When the battery case is applied to GE series cabinet products, this button switch function does not support its use).

⑫ Circuit breaker(OFF/ON)

The circuit breaker is the electrical part with secondary protection on the electrical circuit of the battery. When the circuit breaker is turned OFF, the battery box has no output; When the circuit breaker is ON, the battery box can output power to the outside world.



<b>Model: GE0405</b>		<b>Energy Storage System</b>	
<b>PV Input</b>			
PV Open Circuit Voltage (Voc)	150 Vd.c.		
MPPT Voltage Range	65~145 Vd.c.		
Maximum Input Current	60 Ad.c.		
Rated Input Power	3500 W		
<b>AC Input</b>			
Rated AC Voltage	230 Va.c.		
Rated AC Frequency	50 Hz		
Maximum AC Input Current	50 Aa.c.		
AC Input Voltage Range	175~265 Va.c.		
AC Input Frequency Range	45~65 Hz		
<b>AC Output</b>			
Rated Output Voltage	230 Va.c.		
Rated Output Frequency	50 Hz		
Rated Output Power	3200 W		
Maximum Output Power(@30min)	4000 W		
<b>Battery</b>			
Battery Type	Lithium		
Rated Voltage	51.2 Vd.c.		
Operation Voltage Range	44~56.4 Vd.c.		
Maximum Charging Current	100 Ad.c.		
Maximum Discharging Current [A]	100 Ad.c.		
<b>General Data</b>			
Ingress Protection	IP20		
Operating Temperature Range	-10°C~40°C		
Altitude [m]	<2000		
Topology	Low Frequency Isolation		
SN:		MAC:	
MADE IN CHINA			

**GE0405 ESS**

<b>Model: GE0610</b>		<b>Energy Storage System</b>	
<b>PV Input</b>			
PV Open Circuit Voltage (Voc)	250 Vd.c.		
MPPT Voltage Range	65~245 Vd.c.		
Maximum Input Current	70 Ad.c.		
Rated Input Power	4200 W		
<b>AC Input</b>			
Rated AC Voltage	230 Va.c.		
Rated AC Frequency	50 Hz		
Maximum AC Input Current	50 Aa.c.		
AC Input Voltage Range	175~265 Va.c.		
AC Input Frequency Range	45~65 Hz		
<b>AC Output</b>			
Rated Output Voltage	230 Va.c.		
Rated Output Frequency	50 Hz		
Rated Output Power	4800 W		
Maximum Output Power(@30min)	6000 W		
<b>Battery</b>			
Battery Type	Lithium		
Rated Voltage	51.2 Vd.c.		
Operation Voltage Range	44~56.4 Vd.c.		
Maximum Charging Current	150 Ad.c.		
Maximum Discharging Current [A]	200 Ad.c.		
<b>General Data</b>			
Ingress Protection	IP20		
Operating Temperature Range	-10°C~40°C		
Altitude [m]	<2000		
Topology	Low Frequency Isolation		
SN:		MAC:	
MADE IN CHINA			

**GE0610 ESS**

# Part 3. Product Installation

<b>Model: GE0810</b>		<b>Energy Storage System</b>	
<b>PV Input</b>			
PV Open Circuit Voltage (Voc)	150 Vd.c.		
MPPT Voltage Range	65-145 Vd.c.		
Maximum Input Current	80 Ad.c.		
Rated input Power	4800 W		
<b>AC Input</b>			
Rated AC Voltage	230 Va.c.		
Rated AC Frequency	50 Hz		
Maximum AC Input Current	50 Aa.c.		
AC Input Voltage Range	175-265 Va.c.		
AC Input Frequency Range	45-65 Hz		
<b>AC Output</b>			
Rated Output Voltage	230 Va.c.		
Rated Output Frequency	50 Hz		
Rated Output Power	6400 W		
Maximum Output Power(@30min)	8000 W		
<b>Battery</b>			
Battery Type	Lithium		
Rated Voltage	51.2 Vd.c.		
Operation Voltage Range	44-56.4 Vd.c.		
Maximum Charging Current	190 Ad.c.		
Maximum Discharging Current [A]	200 Ad.c.		
<b>General Data</b>			
Ingress Protection	IP20		
Operating Temperature Range	-10°C~40°C		
Altitude [m]	<2000		
Topology	Low Frequency Isolation		
			
SN:		MAC:	
MADE IN CHINA			







GE0810 ESS

**⚠ Attention**

- Due to product version upgrades or other reasons, the contents of this document will be updated irregularly. Unless otherwise agreed, this document serves as a guide only, and all statements, information and recommendations in the document do not constitute any express or implied warranty.
- Please read the GE User Manual carefully before installing the equipment for product information and safety precautions.
- Please install and use the equipment in accordance with this document and the user's manual, or the equipment may be damaged. Insulation tools must be used when installing equipment.

### 3.1 Sparepart List

Before installation, please check that the appearance of the machine is in good condition, and check that the parts of the attachment package are in accordance with the list.

Sparepart List			
Item	Picture	Name	Quantity
1		Expansion bolt M6, install screw -box, length 50mm, casing tube 35mm.	10
2		M4*6/Carbon steel/Nickel plated/chamfered hexagon socket screw with large flat head.	21
3		M4*10/ Carbon steel/Nickel plated/cross round head combination screw.	12
4		Tube terminal E10-12.	2
5		Tube terminal E6010.	9
6		Cold rolled Oterminal for grounding wire.	1

### 3.2 Notes before Installation

This manual contains important information about the installation and safe operation of this product. Before installation, please follow below instructions:

Please Follow the instructions for installation, Otherwise there is a risk of damage to equipment and wires, Due to the heavy weight of the equipment, two adults are required to cooperate with the installation.

#### 3.2.1

Check if the installation site ambient temperature is in the specified range of -20 °C ~ + 55 °C(recommended at 0 °C ~ 40 °C). If the product works below 0 °C for a long time, the service life of the battery will be reduced.

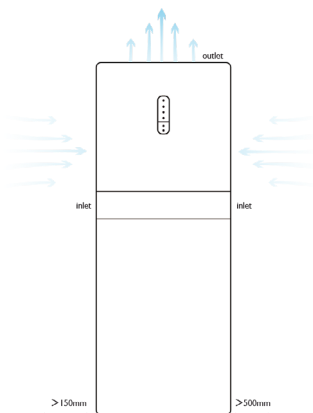

#### 3.2.2

The area where the products are placed should be well ventilated and keep away from dangerous goods such as water, combustible gases, corrosives, etc. Installation and operation in salt fog environment is prohibited.

#### 3.2.3

It is forbidden to tilt or put the product on the side, and keep the air inlet and outlet on both sides well ventilated, as shown in the following figure.

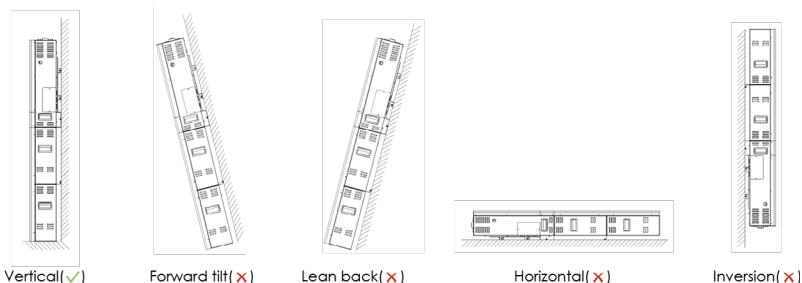

#### 3.2.4

The installation location of the product should avoid sun, rain, snow, etc.



#### 3.2.5

Need to be installed by a professional.

#### 3.2.6

If the product is disassembled and used at low temperature or high humidity, there may be condensation of water droplets. Be sure to wait until the interior of the product is completely dry before installing and using it, or there is a danger of electric shock.

#### 3.2.7

In any emergency, please stop charging and discharging immediately and disconnect the circuit breaker.

#### 3.2.8

All power outlets should be connected to the protective ground wire.

### 3.3 Tool Preparation

This manual contains important information about the installation and safe operation of this product. Before installation, please follow below instructions:

	Cross Screwdriver	Word Screwdriver	Insulated Movable Wrench
Hoisting Equipment			
		Insulating Protective Shoes	Insulating Tape
		Insulating Gloves	Steel Tape Measure
		Rubber Hammer	Wire Stripping Forceps
		Wire Pressing Forceps	Crystal Head Crimping Forceps
		Hydraulic Pliers	M4 Allen wrench

### 3.4 System Installation

#### 3.4.1 Component Parts:

**⚠ Attention**

GE0610 and GE0810 contain two battery boxes. The default configuration and parameters of the battery box are the same.

Before installation, you need to set the dial address in advance (please refer to section 5.3 for the setting method).

Select one battery box to set its dial address to 0000, which is called 1#battery box; and the dial address of the other battery box is set to 0001, which is called 2#battery box.

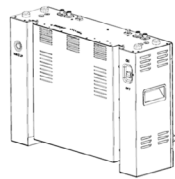
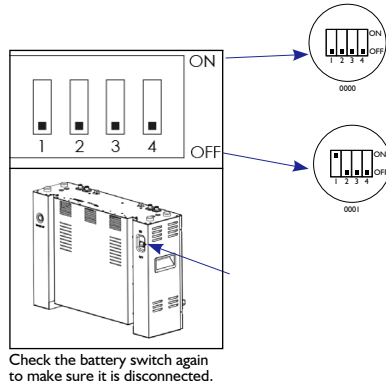

Component 1,  
1# Battery

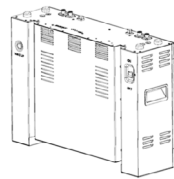

Component 2,  
2# Battery

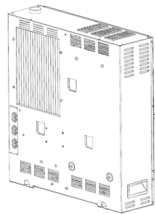

Component 3,  
Inverter



Component 4,  
Wall hanging shelf

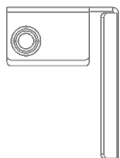

Component 5, Insertion board

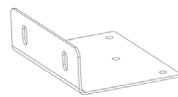

Component 6,  
Fixed frame



Component 7,  
Front cover plate (top)

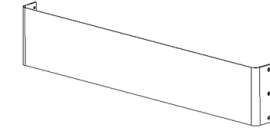

Component 8,  
Front cover plate (middle)



Component 9,  
Front cover plate (bottom)



Component 10, Support Bracket



Component 11, Battery -Parallel positive wire: Hereinafter referred to as BPP cable



Component 12, Battery-parallel negative cable Hereinafter referred to as BPN cable



Component 13, BAT positive output power cable Hereinafter referred to as BAT + cable



Component 14, BMS Parallel communication wire harness Hereinafter referred to as BPC cable



Component 15, Power switch harness



Component 16, Grounding wire

### 3.4.2 Assembly Step:

**⚠ Attention:** Before installation, be sure to check whether the ground and wall are smooth and flat, and whether the wall is perpendicular to the ground and into a 90 degree Angle, If these conditions are not met, it may have a bad effect on the installation.

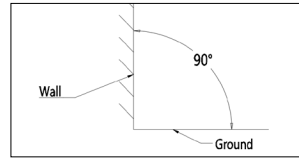

#### 3.4.2.1 1# Battery Box installation

a) Put 1# battery box at flat surface, 40mm distance from the mounting wall. (Figure 1)

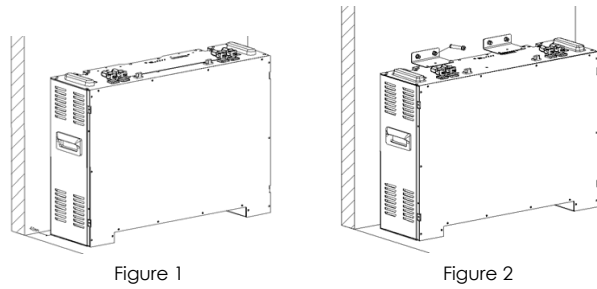

b) Install the fixed frame on the battery case, mark the hole position on the wall with a marker pen, then remove the battery case, punch four holes in the corresponding marked position with a percussion drill, then insert the M6 expansion bolt in turn and hammer in, then put the battery pack to the pre-installed location, tighten the M4 screws with wrench. (Figure 2)

c) Plug quick plug terminal head of "BAT+" cable in "BAT+ 1" terminal.

"BPP" connect "BAT+2" terminal,  
 "BPN" connect "BAT-1" terminal,  
 Connect the end "A" of power switch harness to the wake-up terminal,  
 "BPC" cable connect "CAN2" terminal; (Figure 3)

**⚠ Notice:** the terminal of "BPP" and "BPN" is designed with lock function, when connect please press the terminal hard until you heard the sound of locking.

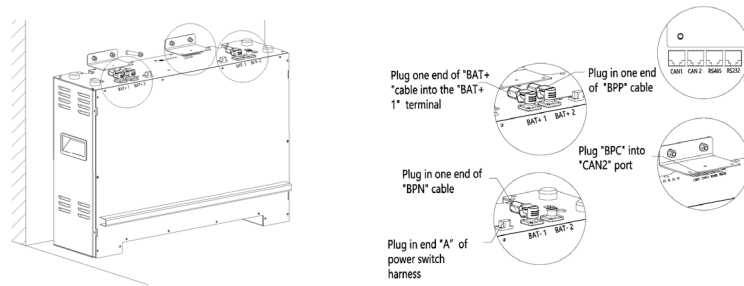

Figure 3

#### 3.4.2.2 2# Battery installation

Stack gently 2# battery on the top of the 1# battery drill holes and install the fixed frame . insert the expansion bolt tighten the screws, ensure the Battery box is attached to the wall firmly .(Figure 4) .

**⚠ Note:** please don't connect cables which comes from 1# battery firstly.

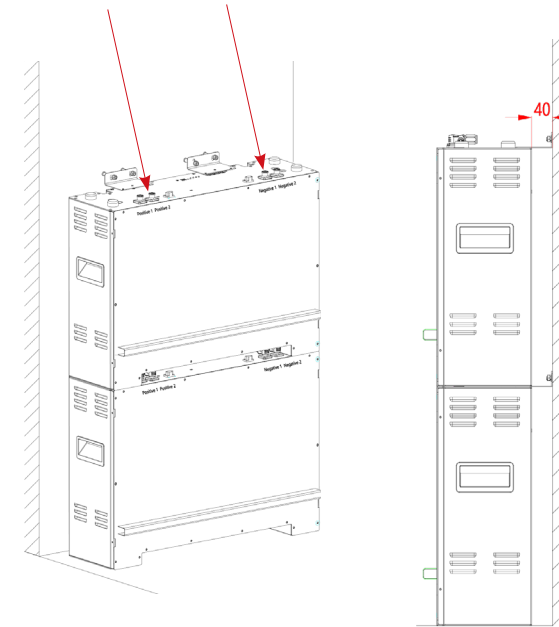

Figure 4

### 3.4.2.3 Wall-hanging shelf installation

1. Find out the location of the hole and punch the hole according to the layout diagram note: The hole position is symmetrical.
2. install wall-hanging shelf and tighten the screw.(Figure 5)

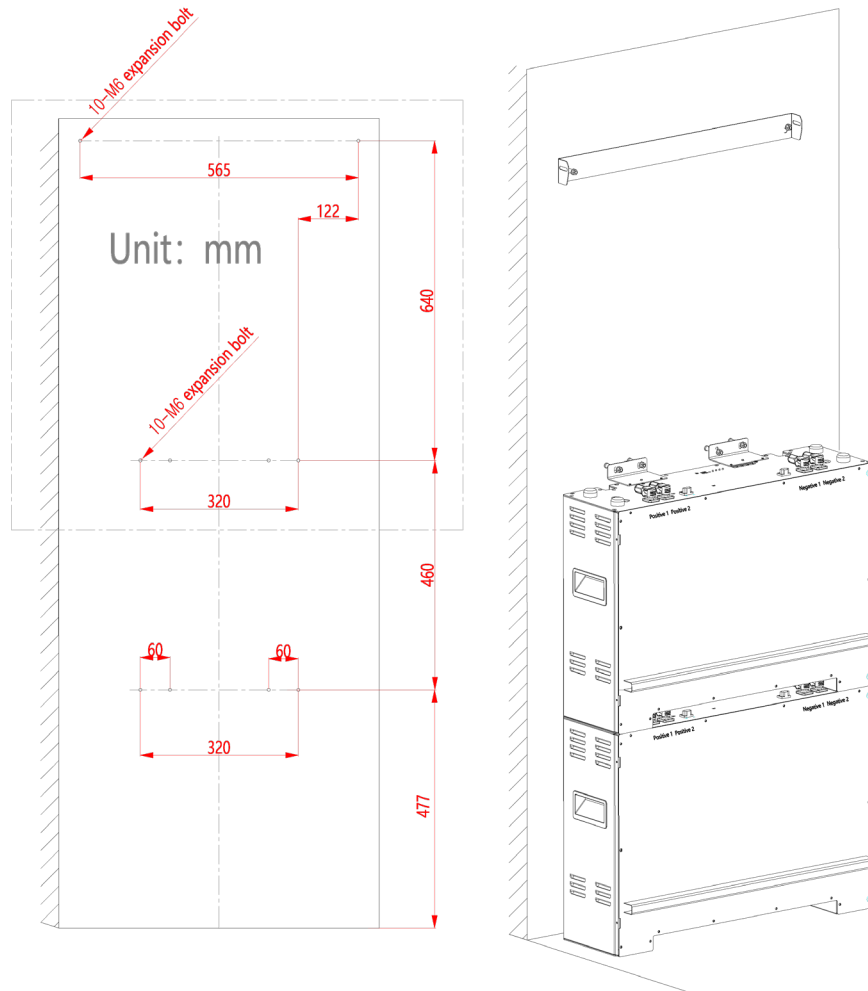

Figure 5

### 3.2.2.4 Inverter case installation

1. Stack inverter box gently on the top of battery, note the limit bottom hole , figure ① shown as above for reference.
2. Plug insertion board to connect inverter box and wall-hanging shelf together. see figure ② .
3. Tighten the M6\*16 screw ensure inverter box is fixed to the wall, see figure ③④ .(Figure 6)

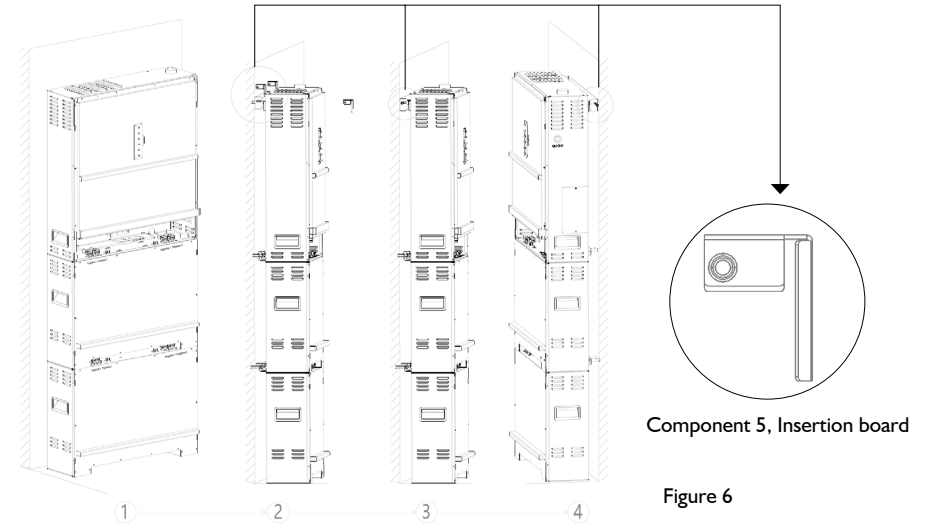

Figure 6

### 3.2.2.5 inverter case wiring connect

Connect BPP cable/ BPN cable/ BPC (Note that all wiring runs through the back of the battery through the hole as shown in the picture) (Figure 7).

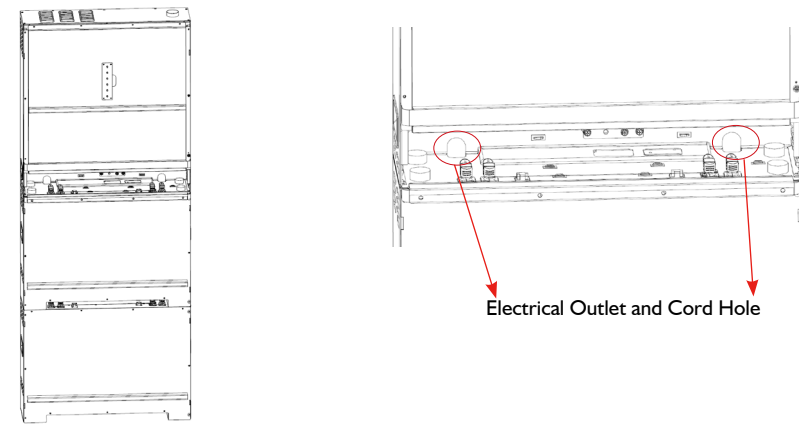

Figure 7



"BAT-" connect "BAT-2" terminal, "BPP" connect "BAT+2" terminal ("BAT- cable" is reserved in the inverter box).  
 "BPN" connect "BAT-1" terminal, "BPC" Connect "CAN1" terminal  
 "BAT+" cable connect copper bar, "BEC" cable ("BEC cable" is reserved in the inverter box) connect "RS485" terminal .(Figure 8)

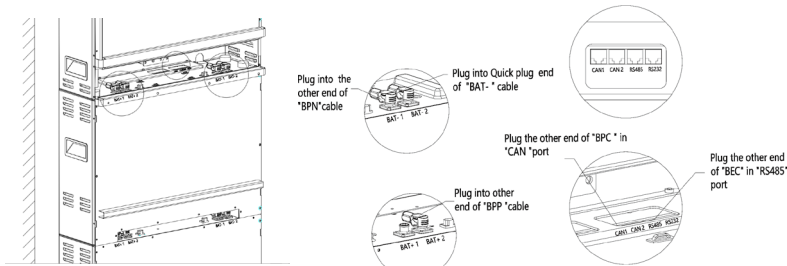

Figure 8

Connect the end "B" of power switch harness to the "wake-up" terminal, End "C" connect End "D" ("End D" is reserved in the inverter box).(Figure 9)

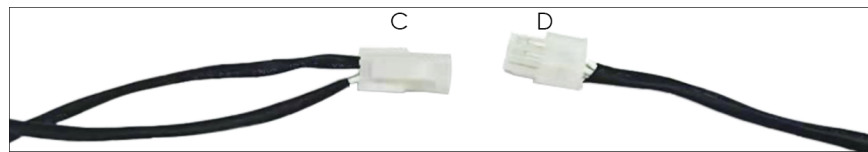

Figure 9

### 3.2.2.6 Grounding Wire Connection

Using grounding wires connect battery and inverter, battery and battery respectively, and tighten the screw(connection position as shown).(Figure 10)

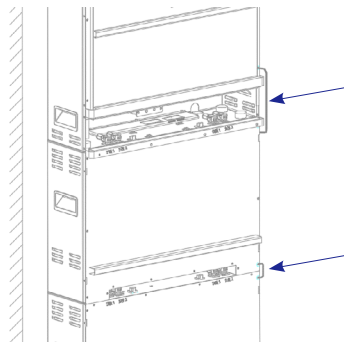

Figure 10

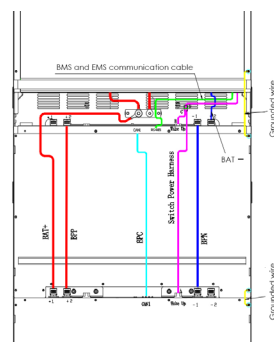

Figure 11

### 3.2.2.7. System Wiring Perspective (Figure 11)

### 3.2.2.8. Install Support Frame

Place the support frame as shown in the figure. Screw the four positions "A, B, C and D" and fix them on the panel .(Figure 12)

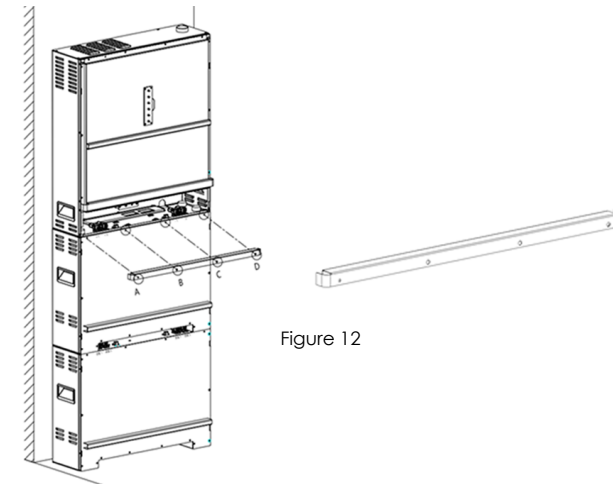

Figure 12

### 3.2.2.9 Install Front Cover Plate

Install the front cover plate of the top, bottom and middle respectively, then cover the fixing screw; (figure 13)

21 M4\*12 countersunk head screws for side fixing.

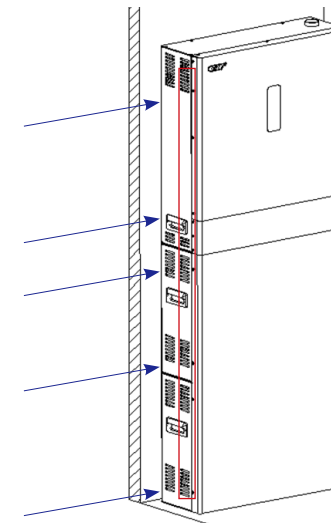
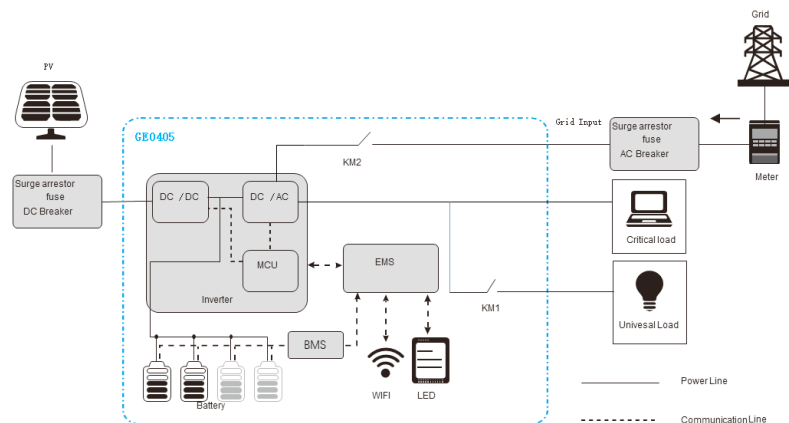

Figure 13

# Part 4. Electrical connection



- PV: photovoltaic module;
- KM: Relay;
- Meter: Electric meter;
- Inverter: Bi-directional inverter;
- Grid: Utility Grid;
- EMS: Energy Management System.

**⚠ Note:** The output circuit “AC Output1” and “AC Output2” are of the same electrical specification, and the single output can reach the rated power value of the equipment.  
The total load power is not allowed to exceed the inverter rated power when these two terminals connect loads simultaneously .

## 4.2 PV wiring

**⚠ Attention**

- Make sure that the external PV switch is in the off state when connecting the PV strings.
- Make sure the PV string polarity matches the PV connector, otherwise the product will be damaged.
- Ensure that under no circumstances the maximum open circuit voltage of each PV cluster is higher than the maximum input voltage of the inverter.
- Ensure that the voltage of each PV string is within the MPPT voltage range.
- It is forbidden to connect PE wire (ground wire) with positive and negative poles of PV strings, otherwise it will cause product damage.

## PV series voltage range

Item	GE0405	GE0610	GE0810
Maximum open circuit voltage	150V	250V	150V
MPPT voltage range	65-145V	65-245V	65-145V
Number of MPPT	1		
Recommend cable	6AWG		

PV wiring position of all-in-one energy storage machine is located on the left user wiring panel of all-in-one machine, as shown in the figure below :

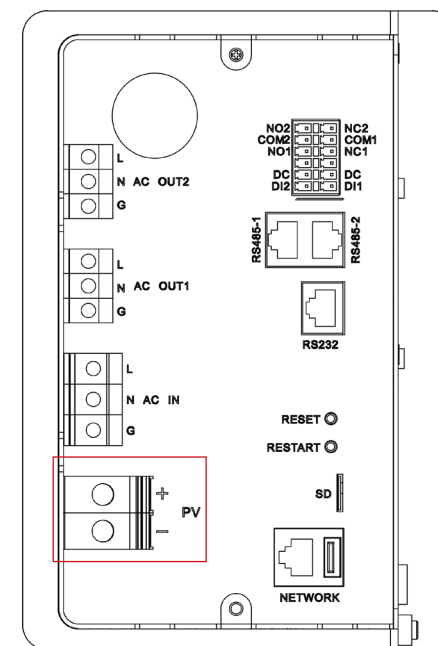

PV cable installation method is as follows:

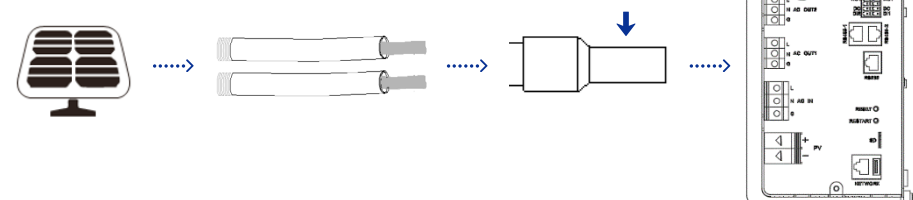

### 4.3 AC wiring

Please select the appropriate external wiring according to the local electrical code. The figure below is for reference only.

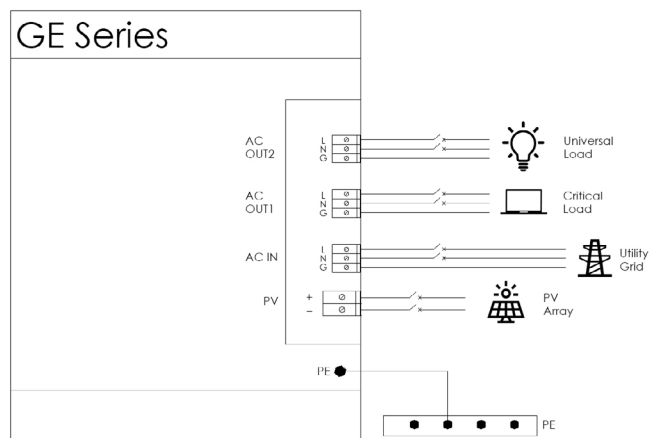

**Note**

The wiring methods in the local electrical code are different from the above wiring methods, especially for neutral wiring, grounding and RCD. Please contact the distributor or supplier before operating!

#### 4.3.1 Grid wiring

In order to ensure that the energy storage all-in-one machine can be safely and reliably disconnected from the power grid, please install an independent single-pole or two-stage circuit breaker as a protection device (according to local electrical code requirements) before the power grid is connected to the all-in-one machine.

Model	GE0405	GE0610	GE0810
Recommended circuit breaker	63A	63A	80A

For the safety of the system, the GRID line recommended wire specifications are as follows.

Model	GE0405	GE0610	GE0810
Cabling Requirement	10AWG	8AWG	6AWG
Wire stripping size	8mm	9mm	9mm
AC terminal	GTNE	GTNE	GTNE

Please follow the following steps to install wiring:

1. Measure the voltage and frequency of the grid access point to confirm that it conforms to the AC parameter specification of the all-in-one machine.
2. The PE wire (ground wire) of the system must be reliably grounded to ensure that the impedance between the zero wire and ground wire is less than 10 ohms.
3. Verify that the power circuit breaker is disconnected.
4. Verify that the all-in-one machine is in shutdown status.
5. Remove the cover screw from the wiring panel of the user of the all-in-one machine and move the cover plate, as shown in the figure below:

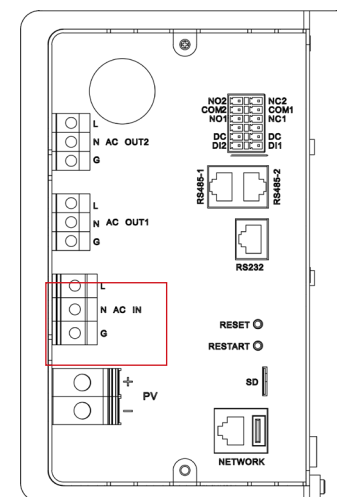

6. Run the cable through the GRID PG connector on the cover plate in turn and use a tool to tighten the AC terminal and cable.
7. Insert the AC terminal into the corresponding terminal on the connection panel and lock it, as shown in the figure below:

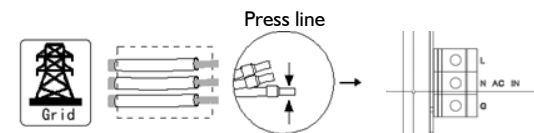

**Note:** L -Live line; N -Neutral line; PE - Ground line.

8. Mounting cover plate.

### 4.3.2 Load wiring

In order to use the load function more safely and reliably and protect the load, please install RCD in the front of the load, please refer to the following:

Model	GE0405	GE0610	GE0810
Recommend RCD	32A/30mA	63A/30mA	63A/30mA

For the safe operation of the system, the recommended wire specifications for the load are as follows.

Model	GE0405	GE0610	GE0810
Cabling requirement	10AWG	8AWG	6AWG
Wire stripping size	8mm	9mm	9mm
AC terminal	GTNE	GTNE	GTNE

Please follow the following steps to install wiring:

1. Confirm that the load voltage and frequency conform to the all-in-one machine specifications.
2. The PE wire (ground wire) under load must be reliably grounded to ensure that the impedance between the zero wire and ground wire is less than 10 ohms.
3. Verify that the power circuit breaker is disconnected.
4. Verify that the all-in-one machine is in shutdown status.
5. Remove the cover screw from the user wiring panel of the all-in-one machine and remove the cover plate, as shown in the figure below.
6. Pass the cable through the load PG connector on the cover plate in turn and use a tool to tighten the AC terminal and cable.
7. Connect the AC terminals to the corresponding terminals on the wiring panel and lock them, as shown in the figure below:

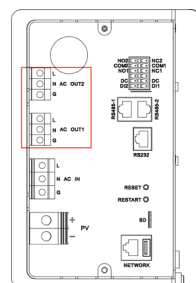

User wiring panel

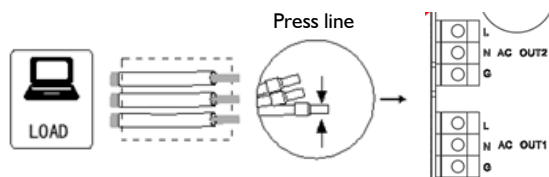

**⚠ Note:** L—Live line, N—Neutral line, PE—Ground line

8. Install the cover plate.

### 4.4 Communication wiring

The communication connection is RJ45, please follow the following steps to install the connection:

1. It is recommended to use the standard super five types of shielded network cable. The cable requires more than 22AWG, and the connector USES 8P8C shielded crystal head.
2. Verify that the power circuit breaker is disconnected.
3. Verify that the all-in-one machine is in shutdown status.
4. Remove the cover screw from the wiring panel of the user of the all-in-one machine and remove the cover plate, as shown in the figure below:

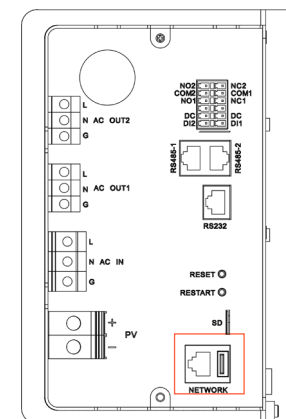

5. The communication NETWORK ports on the wiring panel are ALL RJ45 NETWORK ports with functions of RS232, RS485 and NETWORK respectively.
6. Thread the cable through the COM PG connector on the cover plate in turn. Use tools to press down the crystal head and wire.
7. Insert the crystal head into the corresponding RJ45 network port on the wiring panel, as shown in the figure below:

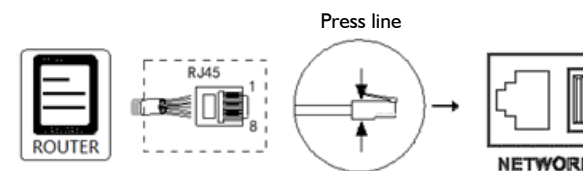

8. Install the cover plate.

### 4.5 Diesel generator connection

Working principle: in off-grid mode, when the battery SOC is below or above the threshold set by us, the inverter will send a dry contact signal to the diesel engine's self-starting device, and the diesel generator will start or stop automatically.

User wiring panel: AC IN is used for direct access of diesel engine output or ATS access. NO2 COM2 /NC2 COM2 are normally open and normally closed contacts respectively, which are used to control the start and stop of DG with the dry contact signal.(Figure 1)

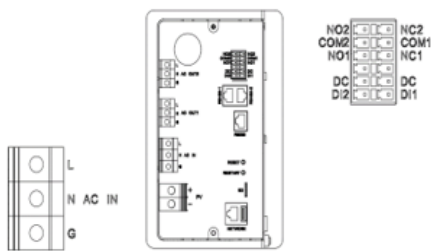

Figure 1



Figure 2

Set the starting and stopping conditions of the diesel engine in the APP.(Figure 2)

#### Detailed control logic:

As shown in the App Configuration page, set "AlarmSOctodgs" to a value such as 10%. (see figure 2)

When the battery SOC is lower than this value, NC2-COM2 contacts becomes open, and NO2 -COM2 will breakover and the diesel generator can utilize the dry contact signal to start working.

When the SOC recovers and reaches or the current SOC exceeds the value of "ALARMSOCDGS\_CLEAR", NC2-COM2 contacts will return to normal-close state, and NO2-COM2 will return to normal-open state; the diesel generator can utilize the dry contact signal to stop working.

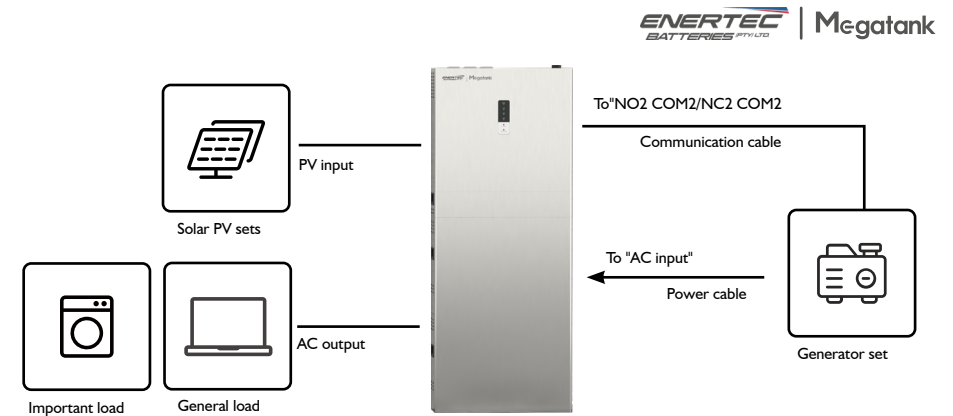

Figure 3

Diesel engine access diagram in pure off-grid mode.(Figure3 )

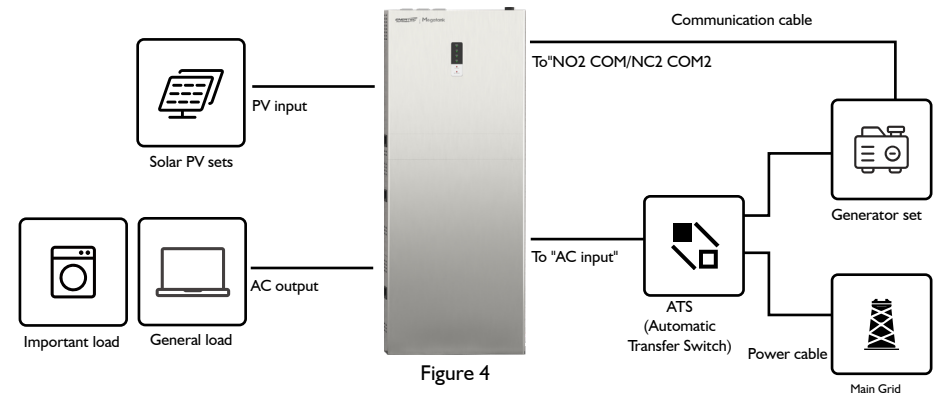

Figure 4

Schematic diagram for simultaneous access of power grid and Diesel engine.(Figure 4)

### 4.6 Ground wiring

For the safety of the system, the enclosure of the energy storage all-in-one machine and the capacity expansion box can be connected by secondary grounding or equipotential. When the original protective conductor fails, it can prevent the contact current during the grounding fault and cause personal harm. The recommended wire specifications for grounding cables are as follows.

Model	GE0405	GE0610	GE0810
Cabling requirement	10AWG	10AWG	10AWG
Wire stripping size	8mm	8mm	8mm
Terminal	The ring terminal M6	The ring terminal M6	The ring terminal M6

Please follow the following steps to install wiring:

1. Verify that the power circuit breaker is disconnected.
2. Verify that the all-in-one machine is in shutdown status.
3. Remove the insulation layer of the ground cable by 8mm.
4. Insert the stripped cable into the ring terminal and press it down with a special tool.
5. Connect the ring terminal to the housing junction of the integrated machine.
6. To lock the ground screw, the torque must be greater than 10N.

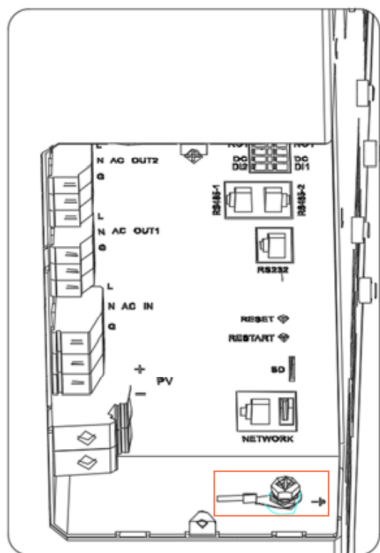

## Part 5. Operation instruction

### 5.1 Working mode

#### 1. PV priority mode

In this case, the load will be preferentially powered by PV and battery. And after the battery power falls below the set value, the load will be powered by the utility. When the PV only charges the battery, and after the battery reaches the set point, the system will switch again to the PV and battery to power the load together.

#### 2. Grid priority mode

The load will be preferentially powered by utility, and the PV will charge the battery to ensure the battery is fully charged, once the grid power is cut off, load will be powered by the ESS.

#### 3. Off-grid mode

PV and battery supply power to the load together. When the battery capacity is lower than the set alarm value, the system will give a low power alarm and output the generator running signal. The generator will supply power to the load and charge the battery to the set value at the same time.

#### 4. Manually charge battery mode

Utilizing PV and grid charge battery as long as PV or grid is available, the charging current can be set and set the total charging current, and the inverter automatically coordinates PV and AC charging power.

#### 5. Intelligent mode

According to the time period, grid priority and PV priority mode are configured in the system. At 24 hours a day, 4 sections can be allocated, each time period is corresponding to the start time, end time and working mode.

#### For example

- 00:00 - 06:00 Grid priority mode
- 06:00 - 12:00 PV priority mode
- 12:00 - 18:00 PV Priority mode
- 18:00 - 24:00 Grid priority mode

### 5.2 Statement of operation

- Please read this chapter carefully before operation.
- Ensure the system wiring is collected.
- Ensure the AC&DC collection terminals are firmly fixed.
- Ensure the external access device parameter is matched with the system.
- It is recommended to turn off the equipment when not in use for a long time.



### 5.3 GE series all-in-one machine switch operation

**Note:** The default configuration address of the battery box is 0000. Please refer to the following table if you need to reconfigure the address.

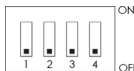
Item	Port	No	Description
Dial switch		1 - 4	<p><b>!</b> "ON" side means "1", "OFF" side means "0".</p> <p>When the system is configured with multiple batteries, "0000~1111" means "address 0~ address 15" respectively.</p> <p>The address can be set from address 1, up to address 8, and can be set anywhere, but no duplicate addresses can appear.</p>

Add	Position				Description
	#1	#2	#3	#4	
0	OFF	OFF	OFF	OFF	Set to Pack1 (master)
1	ON	OFF	OFF	OFF	set to Pack2( slave)
2	OFF	ON	OFF	OFF	set to Pack3( slave)
3	ON	ON	OFF	OFF	set to Pack4( slave)
4	OFF	OFF	ON	OFF	set to Pack5( slave)
5	ON	OFF	ON	OFF	set to Pack6( slave)
6	OFF	ON	ON	OFF	set to Pack7( slave)
7	ON	ON	ON	OFF	set to Pack8( slave)
8	OFF	OFF	OFF	ON	set to Pack9( slave)
9	ON	OFF	OFF	ON	set to Pack10( slave)
10	OFF	ON	OFF	ON	set to Pack11( slave)
11	ON	ON	OFF	ON	set to Pack12( slave)
12	OFF	OFF	ON	ON	set to Pack13( slave)
13	ON	OFF	ON	ON	set to Pack14( slave)
14	OFF	ON	ON	ON	set to Pack15( slave)
15	ON	ON	ON	ON	set to Pack16( slave)

### 5.3.1 Power on

**!** Danger: Pay attention not to touch the terminal during startup operation to avoid electric shock hazard. Power-on steps are as follows:

1. Connect all external wirings (pv, utility grid, load) before turning on the inverter. It is suggested that each group of external wirings has a corresponding switch which are kept off state before powering on inverter.
2. Switch on the "main switch" .
3. Press the POWER switch "POWER" button, and the LED indicator lights up normally.
4. Switch on the PV breaker and grid breaker , and the system enters the operation state.

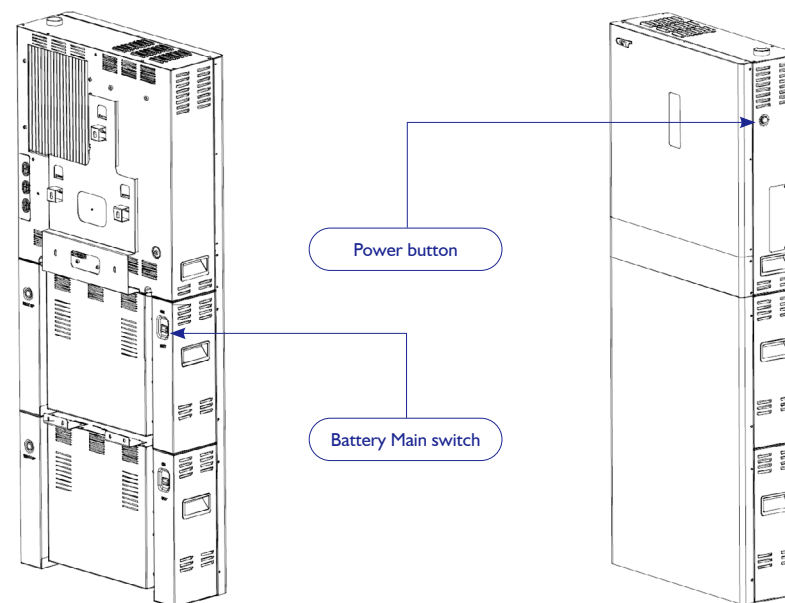

### 5.3.2 Switch off

**!** Do not touch the terminal during shutdown to avoid electric shock hazard. Shutdown steps are as follows:

1. Switch off the load and PV firstly then switch off the Utility grid .
2. Press the "POWER"button then led will be off and the system shut down completed.

### 5.4 Display status

After the system runs normally, the display screen will display the corresponding status. The corresponding display status is described in the following table.

Item	Diagram	Descriptions
1		<p>During system charging, the galloping lamp lights up in turn with SOC increase and cycles. For example, the charging state at 50% is shown below:</p> <p>SOC=50%, the change of charge status indicator light.</p>
2		<p>In the system discharge, the running horse lamp goes out from top to bottom and cycles with SOC decrease. The following figure shows the discharge state at 50%</p> <p>SOC=50%, the change of discharge status indicator light.</p>
3		<p>Blue twinkle: in process of updating                  Red twinkle: Communication between EMS and BMS, inverter or MPPT is abnormal                  Green twinkle: cut off                  Green lighting: normal operation</p>
4		<p>Red lighting: system startup                  Red twinkle: prepare the network connection                  Green twinkle: A wi-fi or wired network has been detected and a router is being connected                  White lighting: connection failure                  Greenlighting: connect successfully</p>

## Part 6. Maintenance and common fault treatment

When you use the product, if it cannot work normally, please do not rush to determine that the product has failed, please refer to the table "Common Fault Handling Table" and "Fault Code Table" to find the cause of the failure. Also, check to see if it is due to external conditions, such as temperature, humidity, or load overload.

### 6.1 Daily maintenance

1. The system starts from the delivery and needs to be charged every 6 months.
2. During use, if the system temperature is abnormal, please check whether the vent is blocked by dust. If blocked, please timely dredge the tuyere.
3. During the storage period of the system, the system shall be regularly checked by professionals to check whether the wiring is loose or falling off, or to clean the surface and interior of the system; If any defect is found, please contact the distributor in time.

### 6.2 Common trouble shooting

Trouble Shooting Table		
Fault Phenomenon	Cause	Solution
Press the switch and there is no response	Internal fault	Contact with the manufacture.
Battery discharge time is short	Low battery	Keep the product charged for more than 3 hours and let the battery be fully charged.
	Overload	Inspect the load details and remove the Noncritical load.
	Battery ages, capacity decrease	Replace battery, contact with manufacture.
Can't discharge or charge	Internal fault	Contact with manufacture.
	Battery over-temperature	Let stand at room temperature for more than 3 hours.

Fault Phenomenon	Cause	Solution
PV Input abnormality	Loose photovoltaic input wiring or abnormal photovoltaic panel voltage output	Check whether the wiring of photovoltaic input terminal is firm; Check whether the output voltage of the photovoltaic end is normal.
Grid input abnormality	Grid input connection is not tighten , abnormal voltage or frequency	Check whether the wiring of the input end of the power grid is firm; Check if input voltage and frequency are normal.
Battery input abnormality	Communication disconnect, high pressure, low pressure, high temperature, low temperature and over current alarm or fault protection	Check whether the battery communication is normal, check whether the event record has alarm or failure protection.
Fault prompt	Other	To find out the corresponding fault causes, and eliminate one by one.

If the problem still cannot be solved, please contact the distributor or supplier as soon as possible. Note: Do not disassemble the product by yourself! When you need to report the failure situation to the distributor customer service personnel, please record and inform the following information:

1. Product Model.
2. Product Serial No.
3. Date of failure, complete problem description (including fault code, buzzer condition, power network condition, load capacity, etc.)

## Part 7. Packing, Transportation and Storage

### 7.1 System packing

- The system is packed in carton boxes with PE bags inside, moistureproof and waterproof. EPE pearl cotton foam pad is used in the middle to prevent damage to the system during handling and transportation.

### 7.2 System handing and transportation

- Transport must comply with UN UN3481 dangerous goods transport and local laws and regulations.
- Transportation temperature: -10 °C~ 40 °C.
- Equipment and packaging cannot be watered, so it cannot be transported in the open air.

### 7.3 System store

- Storage temperature: -20 °C~ 60 °C.  
Storage humidity: ≤85%RH.
- Storage rooms should be kept ventilated.
- The room should be clean and dry, and prevent the erosion of dust and moisture.
- Room floor bearing weight > 1500KG/m<sup>2</sup>.
- Storage time can not exceed 6 months, otherwise it is recommended to charge and discharge the system.
- The storage room does not have direct sunlight on the system.
- The storage room should have windows to facilitate regular inspection and record relevant environmental data and storage time.

# Appendix: Parameters

GE Series All-in-one Energy Storage System Specifications			
Parameter	GE0405	GE0610	GE0810
<b>PV Input</b>			
Max.recommended DC power[kW]	4.5kW	5.4kW	6kW
Max.DC voltage[V]	150V	250V	150V
Max.charging current[A]	60A	70A	80A
Max. short circuit current[A]	40A	80A	80A
MPPT voltage range[V]	65V - 145V	65V - 245V	65V - 145V
No. of MPP trackers	1	1	1
<b>AC Input</b>			
Nominal AC power [kW]	6kW	8.4kW	11.5kW
Max. AC power [kW]	9kW	13kW	17kW
Rated grid voltage (AC voltage range) [V]	230V (175V - 265V)		
Rated grid frequency [Hz]	50/60Hz (45Hz - 65Hz)		
Nominal AC current [A]	27A	38A	52A
Max. AC current [A]	41A	59A	77A
<b>Battery</b>			
Battery type	LiFePO <sub>4</sub>		
Battery voltage range [V]	44V - 58.4V		
Recommended battery voltage [V]	51.2V		
Battery Capacity(Ah)	100Ah	200Ah	200Ah
Recommended charging/discharging current [A]	50A	100A	100A
Max.charging/discharging current [A]	100A	150A	200A
Communication interfaces	RS232 / RS485 / CAN		
Design cycle life	Over 5000 cycles (Under certain test conditions)		
Parallel operation	Yes, up to 15 batteries, max 76.8 kWh		

AC OUTPUT (LOAD)			
Nominal AC power [kW]	3.2kW	4.8kW	6.4kW
Max. AC power [kW]	4kW	6kW	8kW
Peak power @5sec [kW]	6.4kW	9kW	12kW
	(Test with resistive loads only)		
Rated grid voltage (AC voltage range) [V]	220V - 240V ± 2%		
Rated grid frequency [Hz]	45Hz - 60Hz ± 0.05%		
Nominal AC current [A]	15A	22A	30A
Max. AC current [A]	18A	28A	37A
Switch time[ms]	<4ms(15ms in weak AC source mode)		
Total harmonic distortion (THD, linear load) [%]	<3%		
Parallel operation	Yes		
Load shedding <sup>[1]</sup>	Yes		
<b>PROTECTION</b>			
Inverter	Overload / Output short circuit / PV array reverse polarity / PV over voltage / Equipment Over temperature		
Battery	Over Current / Over Voltage / Temperature		
<b>ENVIRONMENT LIMIT</b>			
Protection class	IP20		
Operating temperature range [°C]	-10°C - 40°C		
Altitude[m]	≤2000m		
Storage temperature[°C]	Recommended 0°C - 35°C		
Noise emission(typical) [dB]	<30dB		
<b>GENERAL INFORMATION</b>			
Dimensions(WxHxD) [mm]	650×1160×214mm	650×1620×214mm	650×1620×214mm
Weight[kg]	110kg	160kg	165kg
Cooling concept	Intelligent air cooling		
Topology	Low frequency isolation		
Communication	WIFI / Ethernet(RJ45)		
Display	LED, APP		
Certificate	UN38.3, IEC62619		
[1] The AC OUT1 for dual-output models is used to connect critical loads. The AC OUT2 is used to connect to non-critical loads. when battery discharge/ charge and reaches the lower/upper limit soc,the AC OUT2 will disconnect/connect its load. User can set the threshold soc respectively through the APP.			